

XAL-53

Hazardous Location Pull Station



Conventional Initiating Devices

Applications

KILLARK® fire alarm stations are suitable for:

- Hazardous areas due to the presence of flammable gases or vapors, combustible dusts or easily ignitable fibers or flyings.
- Installation at petroleum refineries, chemical and petrochemical plants, storage areas, and other processing facilities where hazardous substances are handled and stored.
- Areas where emergency control of fire alarm or signal circuits is required.

Features

- Enclosure is made of copper-free aluminum alloy.
- Conduit openings are 3/4" (19.05 mm) NPT feed-through.
- Red, textured powder epoxy paint finish is standard on box and cover and provides high visibility for alarm station.
- Universal (1) normally open and (1) normally closed contact furnished standard.
- Bilingual nameplates included per CSA requirement.
- Internal ground screw is standard.
- Wiring range is #12 AWG through #24 AWG, solid or stranded.

Operation

The alarm station is activated by lifting the front cover and pulling down ring. This quick, easy-to-use two-step process prevents unintentional operation. Operator is reset by depressing shaft and returning plate to original position.

Hazardous Area Classifications

- Class I, Division 1 and 2, Groups C and D.
- Class I, Zones 1 and 2, Groups IIB, IIA.
- Class II, Division 1 and 2, Group E, F, and G.
- Class III, Hazardous Locations.
- NEMA 7CD, 9EFG.

Operational Data

This enclosure is made of cast, copper-free aluminum alloy. It is suitable for: Class I, Groups C and D; Class II, Groups E, F, and G; and Class III hazardous locations. All installations must comply with applicable local and/or National Electrical Code.

Like all electromechanical devices, these control stations require occasional maintenance. Parts may wear out or become defective due to adverse environmental conditions. See Maintenance Data below.

Maintenance Data

CAUTION: Disconnect this device from the supplying circuit before removing the cover.

1. To prevent corrosion, lubricant should be occasionally applied, as follows:

- Killark® "LUBG" lubricant to box/cover flanges.



XAL-53

Explosion-Proof Pull Station with Pull Ring

- Dow Corning Molykote™ 33 Grease, light consistency, to operator shaft.
- 2. Keep all flanges clean and free of scratches.
- 3. Some internal service parts are available. Consult the Killark factory for parts breakdowns.

Agency Listings and Approvals

These listings and approvals apply to the modules specified in this document. In some cases, certain modules or applications may not be listed by certain approval agencies, or listing may be in process. Consult factory for latest listing status.

- **UL Listed:** E50498
- **ULC Listed:** E50498
- **CSA:** LR31085
- **CSFM:** 7150-1439:100

Contact Arrangement

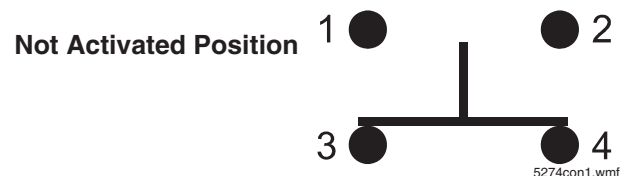

Contact Block Rating

AC						DC		
Volts	Make Amperes	VA	Break Amperes	VA	Continuous Carrying Amperes	Volts	Make Break	Continuous Carrying Amperes
120	60	7200	6.0	720	10	125	1.10	10
240	30	7200	3.0	720	10	250	0.55	10
480	15	7200	1.5	720	10	600	0.20	10
600	12	7200	1.2	720	10			

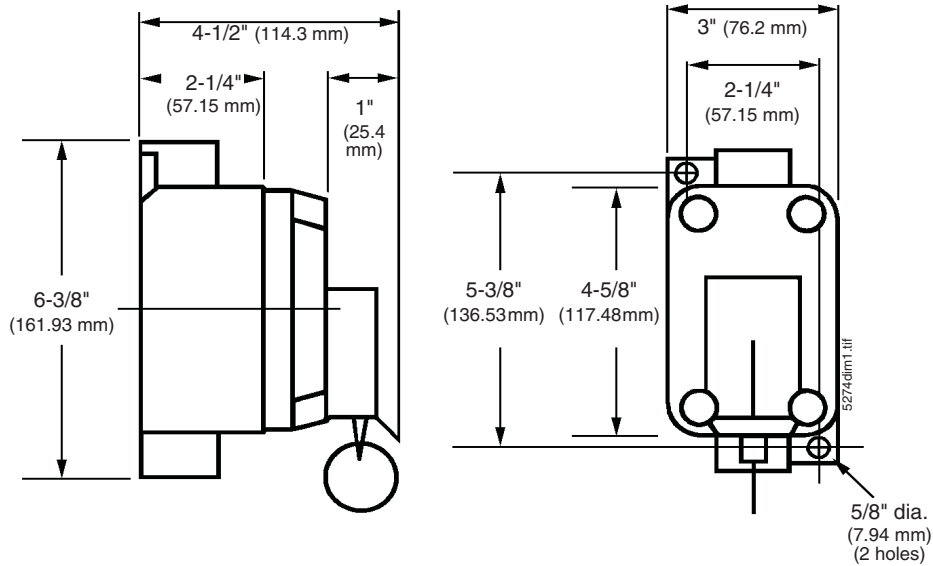

Product Line Information

XAL-53: Explosion-proof, N/O and N/C Contacts.

Notifier is a registered trademark of Honeywell International Inc. **KILLARK®** is a registered trademark of Hubbell®. **Molykote™** is a trademark of the Dow Corning Corporation.
©2010 by Honeywell International Inc. All rights reserved. Unauthorized use of this document is strictly prohibited.



This document is not intended to be used for installation purposes.
We try to keep our product information up-to-date and accurate.
We cannot cover all specific applications or anticipate all requirements.
All specifications are subject to change without notice.



Made in the U.S. A.

For more information, contact Notifier. Phone: (203) 484-7161, FAX: (203) 484-7118.
www.notifier.com